

REV	DESCRIPTION	DWN	CHK	DATE
NOTES:				
1. FINISH: _____ ENAMEL PAINT.				
2. CONDITION POINT: _____ GPM @ _____ PSI SUCTION PRESSURE: _____ PSI MIN _____ PSI MAX.				
3. ALL DIMENSIONS ARE SUBJECT TO CHANGE WITHOUT NOTICE: DO NOT USE FOR CONSTRUCTION PURPOSES UNLESS CERTIFIED.				
4. (XX) INDICATE REFERENCE DIMENSIONS.				
5. PIPE SUPPORTS NOT SHOWN FOR CLARITY.				
6. ALL WELDING DONE BY ASME CODE SECTION 9 CERTIFIED WELDERS.				
7. FILL BASE WITH NON-SHRINKING, NON-FERROUS GROUT: FAILURE TO DO VOIDS TIGERFLOW WARRANTY.				
8. ALLOW 12" AROUND SYSTEM FOR SERVICE AND PRV PILOTING.				
9. ISO-KITS ON ALL BRANCHES.				
10. NSF COAT ALL COMPANION FLANGES, WELD ASSEMBLIES AND GROOVED CAPS.				
11. "▲" INDICATES CUSTOMER SPECIFIED DIMENSION				

11	1	COUPLING, GROOVED
10	3	VALVE, CHECK WAFER SILENT CK, BRONZE TRIM - _____"
9	6	VAL, B/FLY, LEVER HANDLE, BF-03, _____"
8	1	ASSEMBLY, TUBING & WIRING, DUPLEX
7	1	ASSEMBLY, SPOOL, FULL SIZE TANK FEED, _____"
6	3	ASSEMBLY, SPOOL, ELBOW
5	1	ASSEMBLY, ESV SKID, _____" MAIN, _____" BRANCHES
4	1	PANEL STAND
3	1	CONTROL PANEL
2	2	VFD, _____ HP, _____ MFG
1	3	PUMP, PACO, SERIES LC MODEL _____ / MOTOR, _____ HP, _____ RPM, _____ / _____ / _____ Hz., ODP

SYM	QTY	PART
-----	-----	------

Parts List

DALLAS, TX 75237
 PHONE: (800) 783-6756
 FAX: (214) 333-2742
 E-MAIL: engineering@tigerflow.com
 WEB SITE: www.tigerflow.com

THIS DOCUMENT CONTAINS INFORMATION THAT IS CONFIDENTIAL AND PROPRIETARY TO TIGERFLOW SYSTEMS, INC. ("TIGERFLOW"). THIS DOCUMENT IS FURNISHED WITH THE UNDERSTANDING THAT THE DOCUMENT AND THE INFORMATION IT CONTAINS WILL NOT BE COPIED OR DISCLOSED TO OTHERS EXCEPT WITH THE WRITTEN CONSENT OF TIGERFLOW. WILL NOT BE USED EXCEPT FOR THE BENEFIT OF TIGERFLOW AND WILL BE RETURNED AND ALL FURTHER USE DISCONTINUED UPON REQUEST FROM TIGERFLOW.

OPTIONAL CONNECTION TYPE (CHECK ONE)	
STANDARD GROOVED END, (SHOWN)	
GROOVED FLANGE, (NOT SHOWN)	
GROOVED COUPLING, (NOT SHOWN)	
OPTIONAL GAUGE STAND (NOT SHOWN) (CHECK ONE)	
ASSEMBLY, GAUGE STAND, _____ QTY, _____" Ø GAUGES	
NONE	
TANK FEED (CHECK ONE)	
ASSEMBLY, TRIPLEX FULL SIZE TANK FEED LINE, (2.5 SPOOLED)	050-TFT-D-01
ASSEMBLY, TRIPLEX FULL SIZE TANK FEED LINE, (3 SPOOLED)	050-TFT-E-01
NONE / OTHER	

TEMPERATURE PURGE LINE ASSEMBLY (NOT SHOWN) (CHECK ONE)	
TRIPLEX (QTY: 3)	050-TPS-A-03
TRIPLEX W/ 26A-D PRV, 10-125 PSI DISCHARGE	050-TPT-B-03
NO-FLOW SWITCH SPOOL (NOT SHOWN) (CHECK ONE)	
	051-FSA-____-01
NONE	
TANK (NOT SHOWN) (CHECK ONE)	
TANK, TIGERFLOW TRG-645, 132 GAL 125 PSI	065-TA-132-01
TANK, TIGERFLOW TRG-646, 185 GAL 200 PSI	065-TA-185-01
SKID MOUNTED, TANK, BLADDER, 132 U.S. GAL, 125 PSI	065-SMT-A-01
SKID MOUNTED, TANK, BLADDER, 185 U.S. GAL., 200 PSI	065-SMT-B-01
OTHER _____	
NONE	

<input type="checkbox"/> SUBMITTAL DRAWING	DSN	M. LERCH	DATE	01/05/04
-ALL DIMENSIONS ARE REFERENCE ONLY -DO NOT SCALE DRAWING	CHK		DATE	
	PRODUCTION #			
<input type="checkbox"/> MANUFACTURING DRAWING	PROJECT NAME			
-LINEAR TOLERANCE ±1/8" -ANGULAR TOLERANCE ±5°	NAME			
	BENGAL TRIPLEX VERTICAL BOOSTER, FULL SIZE TANK FEED, VFD, _____" Ø MAINS, _____" Ø BRANCHES			
-DO NOT SCALE DRAWING -DIMENSIONS ARE IN INCHES -DIMENSIONING PER ASME Y14.5-1994	PAGE NUMBER			
	PAGE 1			
THIRD ANGLE PROJECTION	SCALE	DRAWING #		
	NTS	BTV-C-01V		REV
				A

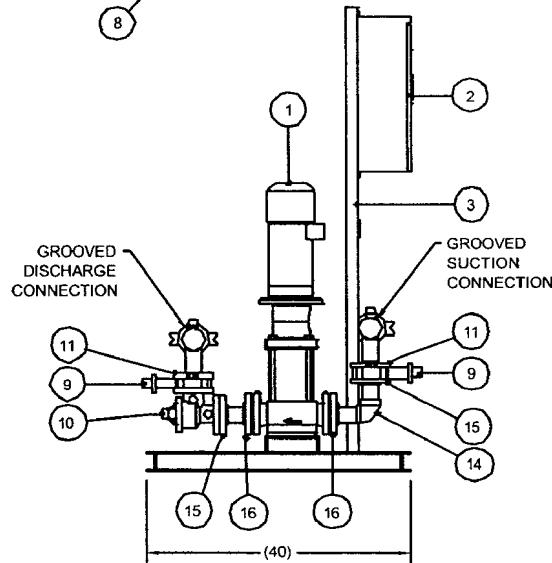
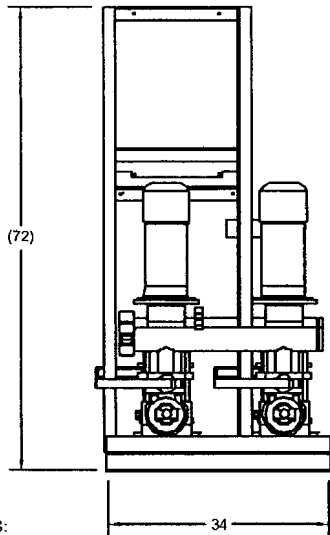
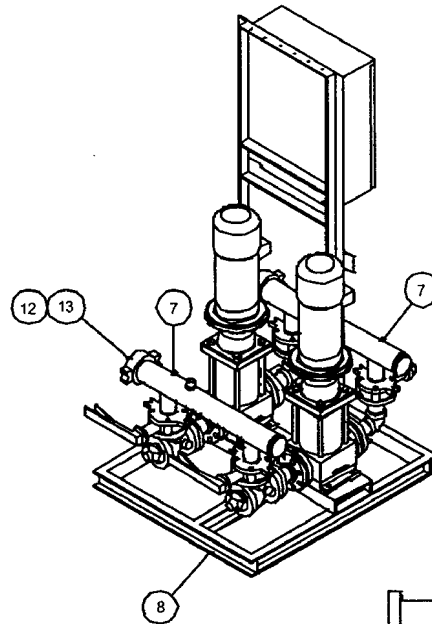
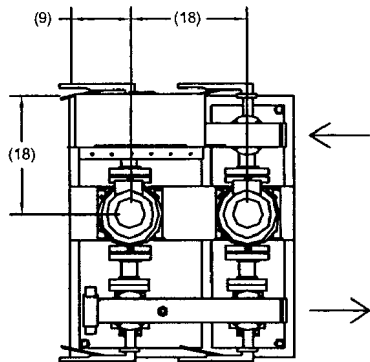

NOTES:

1. FINISH: ORANGE, ENAMEL PAINT.
2. CONDITION POINT: GPM @ PSI
SUCTION PRESSURE: PSI MIN ____ PSI MAX.
3. ALL DIMENSIONS ARE SUBJECT TO CHANGE WITHOUT NOTICE: DO NOT USE FOR CONSTRUCTION PURPOSES UNLESS CERTIFIED.
4. (XX) INDICATE REFERENCE DIMENSIONS.
5. PIPE SUPPORTS NOT SHOWN FOR CLARITY.
6. ALL WELDING DONE BY ASME CODE SECTION 9 CERTIFIED WELDERS.
7. FILL BASE WITH NON-SHRINKING, NON-FERROUS GROUT: FAILURE TO DO VOIDS TIGERFLOW WARRANTY.
8. "▲" IS TO BE A HELD DIMENSION.

18	4	GASKET, RING, NON ABS 1/16"
17	6	NIPPLE, SS S/40 T-304
16	4	FLANGE, RF THRD, SS T-304
15	4	FLANGE, RF THRD, SS T-304
14	2	ELBOW, THRD, 150#, SS T-304
13	2	COUPLING, C-3 FLEX LT WGT, GRVD W/EPDM GSKT, MAX PRES 300#
12	2	CAP (PLUG), STANDARD GROOVED
11	4	ADAPTER, FLANGE, STD, PAINTED, F1
10	2	VAL, PRV/CK, AP, 1115-3, FLANGE 150# DI, STD 20-175 - _____
9	4	VAL, B/FLY, LEVER HNDL, BF-03, 03-121-15-M2 - _____
8	1	ASSEMBLY, SKID
7	2	ASSEMBLY, HEADER
6	1	TUBING ASSEMBLY,-PLASTIC NO-GAUGES
5	1	ASSEMBLY, LOW FLOW BY PASS, DUPLEX
4	1	ASSEMBLY, DUPLEX, TEMP PROBE AND PURGE LINE
3	1	PANEL STAND
2	1	CONTROL PANEL
1	2	PUMP, GRUNDFOS _____ 3600 RPM, _____/_____/60, ODP EFFICIENCY MOTOR

SYM	QTY	PART
-----	-----	------

TIGERFLOW
Engineering Systems to the World

DALLAS, TX 75237
PHONE: (800) 783-6756
FAX: (214) 333-2742
E-MAIL: engineering@tigerflow.com
WEB SITE: www.tigerflow.com

THIS DOCUMENT CONTAINS INFORMATION THAT IS CONFIDENTIAL AND PROPRIETARY TO TIGERFLOW SYSTEMS, INC. ("TIGERFLOW"). THIS DOCUMENT IS FURNISHED WITH THE UNDERSTANDING THAT THE DOCUMENT AND THE INFORMATION IT CONTAINS WILL NOT BE COPIED OR DISCLOSED TO OTHERS EXCEPT WITH THE WRITTEN CONSENT OF TIGERFLOW, WILL NOT BE USED EXCEPT FOR THE BENEFIT OF TIGERFLOW AND WILL BE RETURNED AND ALL FURTHER USE DISCONTINUED UPON REQUEST FROM TIGERFLOW.

<input checked="" type="checkbox"/> SUBMITTAL DRAWING -ALL DIMENSIONS ARE REFERENCE ONLY -DO NOT SCALE DRAWING	DESIGNED BY _____ DATE _____ CHECKED BY _____ DATE _____
	PROJECT NAME _____ NAME _____ MODEL KEY _____
<input type="checkbox"/> MANUFACTURING DRAWING -LINEAR TOLERANCE ±1/8" -ANGULAR TOLERANCE ±5" -DO NOT SCALE DRAWING -DIMENSIONS ARE IN INCHES -DIMENSIONING PER ASME Y14.5-1994	OUTLINE DRAWING # _____ REV _____
THIRD ANGLE PROJECTION SCALE _____ NTS	REV A

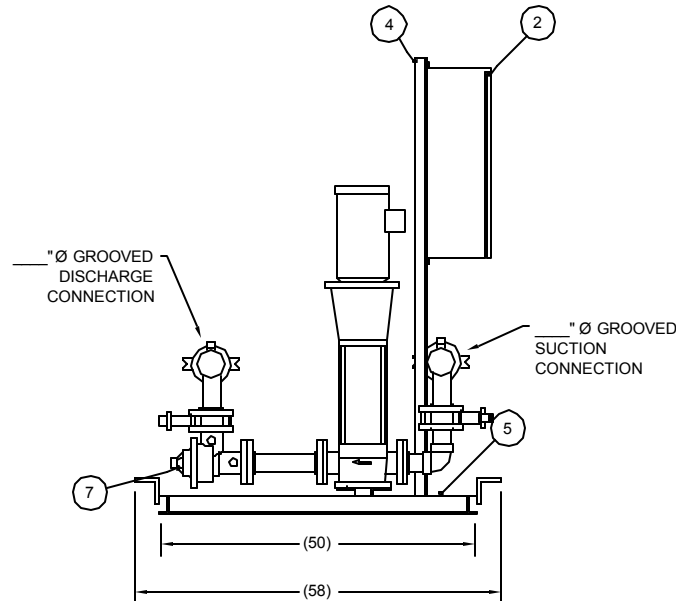
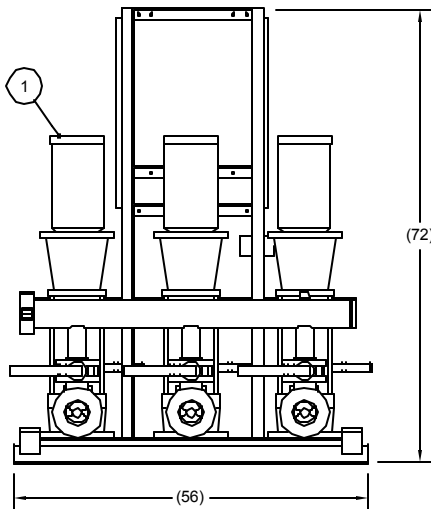
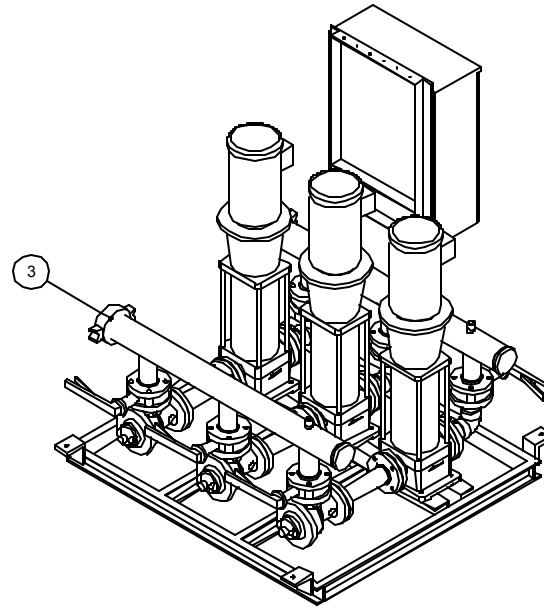
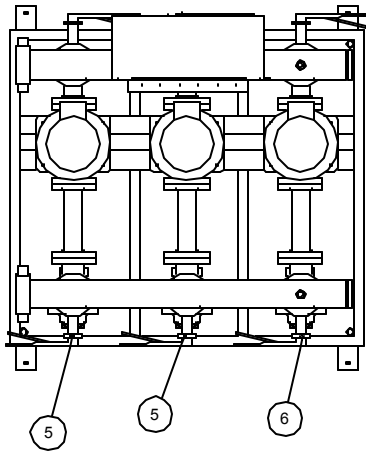

NOTES:

1. FINISH: **ORANGE ENAMEL PAINT.**
2. CONDITION POINT: ___ GPM @ ___ PSI
SUCTION PRESSURE: ___ PSI MIN ___ PSI MAX.
3. ALL DIMENSIONS ARE SUBJECT TO CHANGE WITHOUT NOTICE: DO NOT USE FOR CONSTRUCTION PURPOSES UNLESS CERTIFIED.

CONT.

4. (XX) INDICATE REFERENCE DIMENSIONS.
5. PIPE SUPPORTS NOT SHOWN FOR CLARITY.
6. ALL WELDING DONE BY ASME CODE SECTION 9 CERTIFIED WELDERS.
7. FILL BASE WITH NON-SHRINKING, NON-FERROUS GROUT: FAILURE TO DO VOIDS TIGERFLOW WARRANTY.

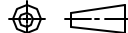
REV	DESCRIPTION	DWN	CHK	DATE
10	2	PLUG, GROOVED		
9	2	COUPLING, GROOVED		
8	4	ANGLE, 4"x4"x5/8" THK, 3" LONG, SPRING MOUNTING		810-040400625
7	3	VALVE, PRESSURE REDUCING / REGULATING, WATTS 1115-3, ___"		
6	6	VALVE, BUTTERFLY, WATTS BF-03, ___"		
5	1	ASSEMBLY, SKID		
4	1	ASSEMBLY, PANEL STAND		
3	2	ASSEMBLY, HEADER, STAINLES STEEL, ___"		
2	1	CONTROL PANEL		
1	3	PUMP, _____, MOTOR, ___ HP @ ___ RPM, ___ / ___ / ___ Hz., ___.		
SYM	QTY	PART		P/N
Parts List				
		DALLAS, TX 75237 PHONE: (800) 783-6756 FAX: (214) 333-2742 E-MAIL: engineering@tigerflow.com WEB SITE: www.tigerflow.com		
THIS DOCUMENT CONTAINS INFORMATION THAT IS CONFIDENTIAL AND PROPRIETARY TO TIGERFLOW SYSTEMS, INC. ("TIGERFLOW"). THIS DOCUMENT IS FURNISHED WITH THE UNDERSTANDING THAT THE DOCUMENT AND THE INFORMATION IT CONTAINS WILL NOT BE COPIED OR DISCLOSED TO OTHERS EXCEPT WITH THE WRITTEN CONSENT OF TIGERFLOW. WILL NOT BE USED EXCEPT FOR THE BENEFIT OF TIGERFLOW AND WILL BE RETURNED AND ALL FURTHER USE DISCONTINUED UPON REQUEST FROM TIGERFLOW.				
<input checked="" type="checkbox"/> SUBMITTAL DRAWING		DSN D. CLARK	DATE 08/30/04	
-ALL DIMENSIONS ARE REFERENCE ONLY -DO NOT SCALE DRAWING		CRK	DATE	
<input type="checkbox"/> MANUFACTURING DRAWING		PROJECT NAME		
-LINEAR TOLERANCE ±1/8" -ANGULAR TOLERANCE ±5°		NAME		
-DO NOT SCALE DRAWING -DIMENSIONS ARE IN INCHES -DIMENSIONING PER ASME Y14.5-1994		MODEL KEY		
THIRD ANGLE PROJECTION		SCALE		DRAWING #
		1:30		REV --

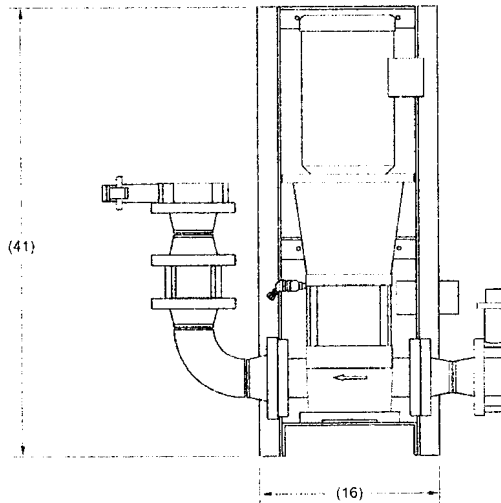
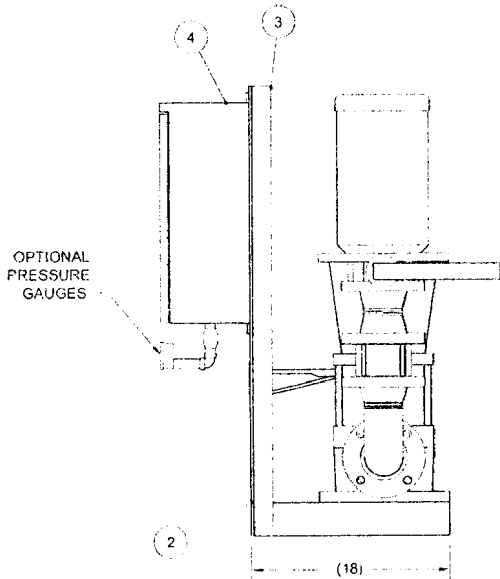
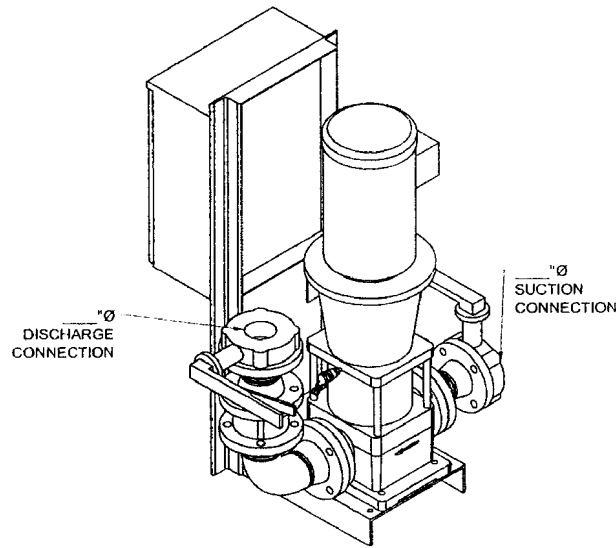
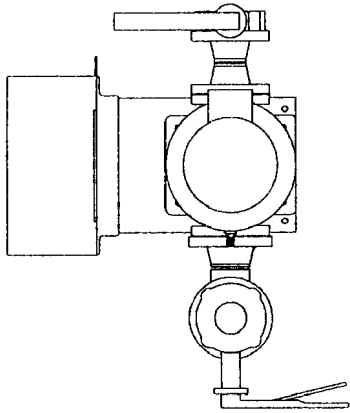

REV	DESCRIPTION	DWN	CHK	DATE
14	1			11-10-025
13	1			BS-40-029
12	1			BS-42-020
11	2			825-0525567
10	1			827-1425
9	1			
8	1			SPOOL-3-TOL-0
7	1			PAGE
6	1			PAGE
5	1			PAGE
4	1			
3	1			STD-10-030-00
2	1			BSS-1218-A
1	1			-

SYM	QTY	PART	P/N
		Parts List	
		GASKET RING, 2"	
		NIPPLE, BRASS, 1/4"xCLOSE	
		ELBOW, NPT, BRASS, 1/4"	
		VAL, B/FLY, LEVER HANDLE, BF-03. 03-121-15-M2 - 2 1/2"	
		VAL, 125# / 250# WAFER SILENT CK, BRONZE TRIM - 2 1/2"	
		ASSEMBLY, TEMP PROBE & PURGE, SIMPLEX	
		ASSEMBLY, SPOOL, 3", NO THREDOLET, WELDNECK FLANGES	
		ASSEMBLY, SPOOL, 3"	
		ASSEMBLY, LOW FLOW BYPASS (NOT SHOWN)	
		ASSEMBLY, ELBOW, 3"	
		CONTROL PANEL	
		ASSEMBLY, PANEL STAND 12"x41"	
		ASSEMBLY, SKID, SIMPLEX	
		PUMP, GRUNDFOS CR32-2-1, _____ HP, _____ RPM, _____ / _____ ODP	



DALLAS, TX 75237
 PHONE: (800) 783-6756
 FAX: (214) 333-2742
 E-MAIL: engineering@tigerflow.com
 WEB SITE: www.tigerflow.com

THIS DOCUMENT CONTAINS INFORMATION THAT IS CONFIDENTIAL AND PROPRIETARY TO TIGERFLOW SYSTEMS, INC. ("TIGERFLOW"). THIS DOCUMENT IS FURNISHED WITH THE UNDERSTANDING THAT THE DOCUMENT AND THE INFORMATION IT CONTAINS WILL NOT BE COPIED OR DISCLOSED TO OTHERS EXCEPT WITH THE WRITTEN CONSENT OF TIGERFLOW. WILL NOT BE USED EXCEPT FOR THE BENEFIT OF TIGERFLOW AND WILL BE RETURNED AND ALL FURTHER USE DISCONTINUED UPON REQUEST FROM TIGERFLOW.

SALES DRAWING		OSN	D. CLARK	DATE	02/16/04
ALL DIMENSIONS ARE REFERENCE ONLY		CHK		DATE	
MANUFACTURING DRAWING		PRECEDENCE #			
		PRECEDENCE NAME			
-LINEAR TOLERANCE ±1/8"		NAME			
-ANGULAR TOLERANCE ±5°					
-DO NOT SCALE DRAWING		ES-3000-MB HORIZONTAL BOOSTER, SIMPLEX. 2-1/2" CHECK VALVE			
-DIMENSIONS ARE IN INCHES		MODEL KEY			
-DIMENSIONING PER ASME Y14.5-1994		DRAWING #			
THIRD ANGLE PROJECTION	SCALE	P-N		REV	--
	1:18				

TANK		
QTY	PART	P/N
	AMTROL ST-210V	14-10-050
	NONE	
	OTHER	
NO PRESSURE GAGES		
PRESSURE GAGES		
1	GAGE, LM 2 1/2", 30"-0-160 PSI	13-10-060
1	GAGE -160 PSI	13-10-070
2	VALVE, 1/4"	13-12-030

NOTES:

1. FINISH: ORANGE, ENAMEL PAINT.
2. CONDITION POINT: _____ GPM @ _____ PSI
SUCTION PRESSURE: _____ PSI MIN _____ PSI MAX.
3. ALL DIMENSIONS ARE SUBJECT TO CHANGE WITHOUT NOTICE: DO NOT USE FOR CONSTRUCTION PURPOSES UNLESS CERTIFIED

CONT.

4. (XX) INDICATE REFERENCE DIMENSIONS
5. PIPE SUPPORTS NOT SHOWN FOR CLARITY.
6. ALL WELDING DONE BY ASME CODE SECTION 9 CERTIFIED WELDERS
7. FILL BASE WITH NON-SHRINKING, NON-FERROUS GROUT: FAILURE TO DO VOIDS TIGERFLOW WARRANTY.
8. SHIM IF NECESSARY.

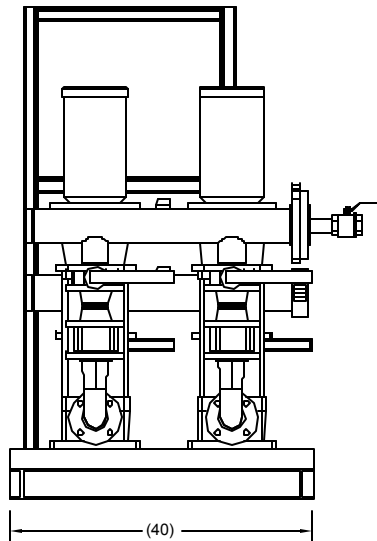
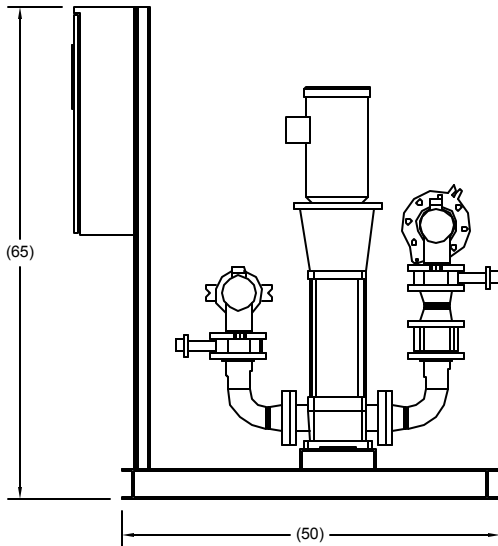
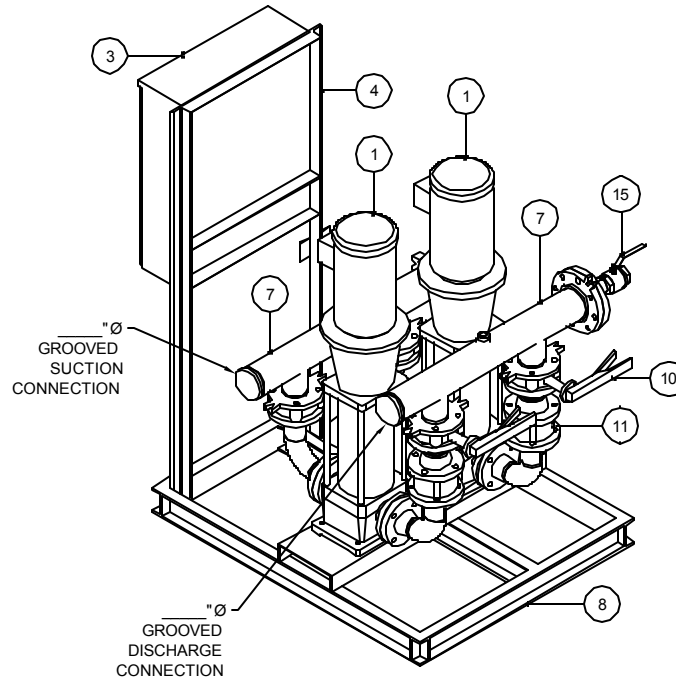
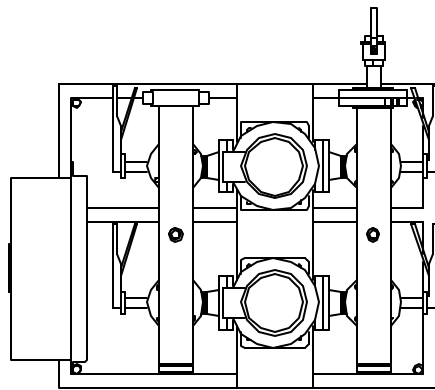

NOTES:

1. FINISH: **ORANGE, ENAMEL PAINT.**
2. CONDITION POINT: _____ GPM @ _____ PSI
SUCTION PRESSURE: _____ PSI MIN _____ PSI MAX.
3. ALL DIMENSIONS ARE SUBJECT TO CHANGE WITHOUT NOTICE: DO NOT USE FOR CONSTRUCTION PURPOSES UNLESS CERTIFIED.

CONT.

4. (XX) INDICATE REFERENCE DIMENSIONS.
5. PIPE SUPPORTS NOT SHOWN FOR CLARITY.
6. ALL WELDING DONE BY ASME CODE SECTION 9 CERTIFIED WELDERS.
7. FILL BASE WITH NON-SHRINKING, NON-FERROUS GROUT: FAILURE TO DO VOIDS TIGERFLOW WARRANTY.

REV	DESCRIPTION	DWN	CHK	DATE
15	1 ASSEMBLY, SPOOL TANK FEED	-	-	-
14	1 FLANGE, GROOVED, CLASS 150, _____"	-	-	-
13	1 COUPLING, C-3 FLEXIBLE, GRVD W/EPDM GSKT, MAX PRES 300# - _____"	-	-	-
12	1 CAP (PLUG), STANDARD GROOVED - _____"	-	-	-
11	2 VALVE, CHECK, WAFER, VAL-MATIC 1403, _____"	-	-	-
10	4 VAL, B/FLY, LEVER HNDL, BF-03, 03-121-15-M2 - _____"	-	-	-
9	2 ASSEMBLY, SPOOL	-	-	-
8	1 ASSEMBLY, SKID	-	-	-
7	2 ASSEMBLY, HEADER, _____"	-	-	-
6	4 ASSEMBLY, ELBOW	-	-	-
5	1 ASSEMBLY, DUPLEX, TEMP PROBE AND PURGE LINE	-	-	-
4	1 ASSEMBLY, PANEL STAND	-	-	-
3	1 CONTROL PANEL	-	-	-
2	2 VFD, _____ HP	-	-	-
1	2 PUMP, _____ / MOTOR, _____ HP, _____ RPM, _____ / _____ / _____	-	-	-

SYM	QTY	PART	P/N
-----	-----	------	-----

Parts List



DALLAS, TX 75237
 PHONE: (800) 783-6756
 FAX: (214) 333-2742
 E-MAIL: engineering@tigerflow.com
 WEB SITE: www.tigerflow.com

THIS DOCUMENT CONTAINS INFORMATION THAT IS CONFIDENTIAL AND PROPRIETARY TO TIGERFLOW SYSTEMS, INC. ("TIGERFLOW"). THIS DOCUMENT IS FURNISHED WITH THE UNDERSTANDING THAT THE DOCUMENT AND THE INFORMATION IT CONTAINS WILL NOT BE COPIED OR DISCLOSED TO OTHERS EXCEPT WITH THE WRITTEN CONSENT OF TIGERFLOW. WILL NOT BE USED EXCEPT FOR THE BENEFIT OF TIGERFLOW AND WILL BE RETURNED AND ALL FURTHER USE DISCONTINUED UPON REQUEST FROM TIGERFLOW.

<input checked="" type="checkbox"/> SUBMITTAL DRAWING	DSN D. CLARK	DATE 08/27/04
-ALL DIMENSIONS ARE REFERENCE ONLY -DO NOT SCALE DRAWING	CHK	DATE
<input type="checkbox"/> MANUFACTURING DRAWING	PROJECT NAME	
-LINEAR TOLERANCE ±1/8" -ANGULAR TOLERANCE ±5°	NAME	
-DO NOT SCALE DRAWING -DIMENSIONS ARE IN INCHES -DIMENSIONING PER ASME Y14.5-1994	OUTLINE	
THIRD ANGLE PROJECTION	SCALE	PAGE NUMBER
	NTS	DRAWING #
		REV 1