



TIGERFLOW®

Engineered Systems to the World

PACKAGED WATER HEATING SYSTEMS



**PREFABRICATED
& FACTORY
TESTED**



**3rd PARTY
CERTIFIED - UL/
C-UL LISTED
SYSTEMS**



**ASME SECTION 9
WELDING**



**SINGLE SOURCE
RESPONSIBILITY**



**ASME CODE
VESSELS**



**OPTIMAL
INSULATION &
JACKETING**



**EFFICIENT
INSTALLATION**



**STANDARDIZED
& CUSTOM
DESIGNS**





Cost-effective engineered packaged water heating systems pre-piped for commercial, institutional, process and industrial applications.



Packaged Water Heating Systems You Can Count On....



Standard Features



ASHRAE 90A-1980 Fully Jacketed & Insulated Tanks
High Efficiency Copper-Fin Water Heaters
Fast response to load demands
Glass Lined Storage Tanks with 5 year warranty
Bronze Circulating Pumps
Copper Interconnecting Piping, Headers
ASME Temperature & Pressure Relief Valve
Isolation Valves - Full Port Ball Valves
Scale Free Performance
3rd Party UL/C-UL Labeled - Total System
ASME Section 9 Certified Welding



Factory Pressure Tested
Start up and Field Testing
Single Source Responsibility
Efficient Installation



Options



Custom Designs
Tank Linings
Pressure Ratings
Outdoor Installations
Custom Piping Configurations



TIGERFLOW®

Engineered Systems to the World



5450 Redbird Center Dr.
Dallas, TX 75237

(800) 783-6756

Tel: (214) 337-8780

Fax: (214) 333-2742

E-mail: TIGERFLOW@AOL.COM

TIGERFLOW, Your expert source for engineered systems...

Factory built & tested **TIGERFLOW** Water Heating Systems are available to precisely fit individual load requirements. Corrosion proof, glass-lined tanks are equipped with life-extending magnesium anode rods. Steel jackets and fiber glass insulation to meet energy efficiency standards of ASHRAE 90A-1980.

An all copper finned heat exchanger provides highly efficient heat transfer surface while assuring scale free performance year after year. The complete **TIGERFLOW** system is factory built, tested and UL/C-UL third-party certified. That means the unit arrives on site meeting and/or exceeding all relevant industry standards, in addition to site performance specifications. Liability and performance risks are eliminated. System designers appreciate the time savings and **TIGERFLOW** expertise built into each project. Coordinated deliveries of third party certified systems make contractor performance penalties and delays inherent in site-built/site-certified systems a thing of the past.

Our promise to you...

Your **TIGERFLOW** factory engineered system will arrive ready to go and operate reliably to the required specifications, with the simplest of site installation.

REPRESENTED BY:



DATE:

PROJECT:

ENGINEER:

REP:

SPECIFICATION FOR PACKAGED HEATING SYSTEM

Furnish and install a **TIGERFLOW** Series WHS-9000, U.L./C-U.L. engineered and packaged water heating system. The system shall be rated for a recovery rate of ____ GPM at a ____ temperature rise.

VALVES

Isolation Valves: Provide individual pump suction and discharge, full port ball isolation valve(s)

Check Valve: Provide a swing type check valve in discharge header

SCALE THERMOMETER

Provide a 9" scale type thermometer. Thermometer shall be adjustable angle type complete with separable well.

INSTANTANEOUS HEATER

Provide an instantaneous heater of size and capacity listed above. Unit shall be constructed utilizing copper finned tubes with easily removable heat exchanger section. Heating section shall be of natural draft construction with burners constructed of stainless steel.

The instantaneous heater controls must conform to ANSI Standard 221.13 as well as the Canadian Gas Association Standard. At a minimum, the controls must include: ignition safeguard, operating temperature control, high water temperature limit, redundant gas valve, water flow sensing switch, gas pressure regulator, and manual gas shut-off valve.

Heater firing mode shall be two-stage for boilers 250,000 BTUH and under or (modulating) (four-stage) for boilers over 250,000 BTUH instantaneous heating unit shall be complete with factory installed bronze circulating pump to provide circulation between heating section and storage section. Return recirculation pump will be supplied by others. Instantaneous heater shall be a Model #_____.

STORAGE TANKS

Provide a Model _____, _____ Gallon _____" Diameter x _____" High, glass-lined storage tank. The glass lining shall be fired on the inside of the tank. Storage tank shall have a minimum working pressure of 150 PSIG. Tank shall be furnished with two inches of insulation meeting ASHRAE 90 Lb. 1992 and encased in a baked enamel steel jacket.

FACTORY PREFABRICATION

Provide each system as a complete package system on a structural steel mounting frame, piped and mounted. Unit shall be factory primed and painted with machine grade finish coat. All welding shall be performed by ASME Section 9 certified welders.

Suction and discharge headers shall be _____" Type "L" copper.

NOTE: System manufacturer shall isolate all ferrous from all non-ferrous materials.

THIRD PARTY TESTING, OSHA REQUIREMENT

The package shall be UL Listed as a system for its intended use, so meeting OSHA Federal Regulations 29 CFR 1910.303 and 399 as well as NFPA Pamphlet #70 (National Electric Code) Article 90-7, City of Los Angeles Approval Code, CMR248 Massachusetts State Plumbing Code Approval.

STARTUP (Optional)

The factory authorized local representative shall provide (2) hours of startup and field training.

WARRANTY

Each **TIGERFLOW** system shall be warranted for a period of (18) months from date of shipment or (12) months from date of startup, whichever occurs first.

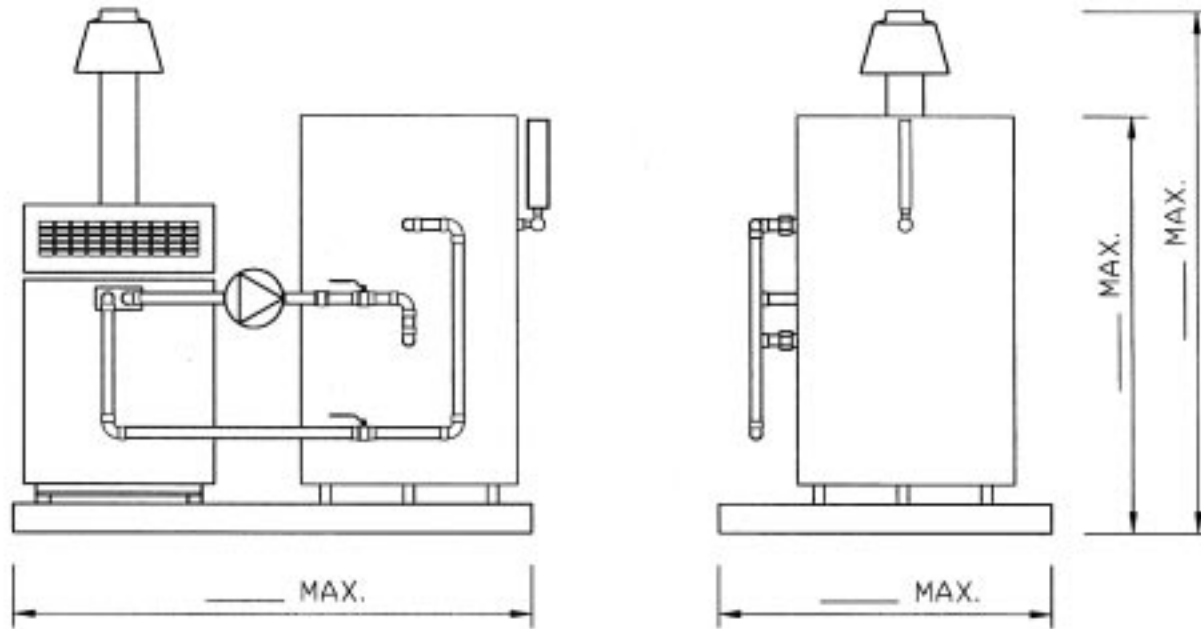

Notes:

1. Dimensions are not for constructions purposes unless certified.
2. All dimensions are $\pm 1/2"$.
3. All dimensions are subject to change without notice.
4. Pipe supports not shown for clarity.
5. All welding done by ASME code section 9 certified welders.

TIGERFLOW Packaged Systems are third party U.L. labeled/C.U.L. labeled as a system to comply with OSHA federal regulations 29CFR1910.303, .399 and NEC #70 Article 90-7

MODEL #: _____

SYSTEM TYPE: _____

PROJECT NAME: _____

DESIGN FLOW: _____

DESIGN PRESSURE: _____



DATE: _____

SCALE: _____

APPROVED: _____

DRAWN BY: _____

REVISION NO: _____